

# 6'-0" x 6'-0" (ACTUAL SIZE) 66 O/A SCALE HOUSE

## Twin Modular Services Inc.

1001 Lower Landing Road Suit 607, Blackwood, NJ

DESIGN BASIS	
State/Jurisdiction	New York
Building Code	Building Code of New York State, 2010 Edition
Plumbing Code	Plumbing Code of New York State, 2010 Edition
Electrical Code	2008 National Electrical Code
Mechanical Code	Mechanical Code of New York State, 2010 Edition

LIFE SAFETY SUMMARY			
Construction type	VB		
Sprinkler Increase, $I_s$	1.00		
Frontage Increase, $I_f$	1.00		
Allowable Area Per Story, $A_A$	900 ft <sup>2</sup>		
Allowable Height Above Grade	2 stories		
	40 ft		
LEVEL	OCCUPANCY	AREA	OCCUPANT LOAD
1	B	36 ft <sup>2</sup>	1

STRUCTURAL DESIGN CRITERIA			
<b>GRAVITY LOADS</b>		<b>SEISMIC (IBC)</b>	
Floor Live	50 psf	Seismic Design Category	D
Floor Dead	10 psf	Site Class	D
Roof Live	20 psf	Importance Category	1.0
Roof Dead	10 psf	Occupancy Category	II
Exterior Wall Dead	5 psf	Mapped Accelerations	
<b>SNOW</b>		$S_s$	0.67
Ground Snow Load	50 psf	$S_1$	0.13
Flat-Roof Snow, $P_f$	38.5 psf	<b>Spectral Response</b>	
<b>WIND</b>		$S_{DS}$	0.56
Wind Speed (3 Second Gust)	90 mph	$S_{D1}$	0.19
Exposure Category	C	Seismic Force Resisting System	A13
Internal Pressure, $G_C$	+/-0.18	Design Base Shear	0.09W
Base Wind Pressure, $P^b$	15.0 psf	Response Modification Factor	6.5ASCE
Mean Roof Height	15 ft	Analysis Procedure	7-05 Sec. 12.8
<b>WIND</b>		<b>FLOOD</b>	
Building shall not be placed on the upper half of a hill or escarpment exceeding 15 feet in height.		Building shall not be located, in whole or in part, in a flood hazard area as established by the authority having jurisdiction unless set on a foundation designed in accordance with ASCE/SEI 25. The flood resistant foundation shall be designed by a registered design professional and constructed to resist all flood loads without transferring loads to the modular structure.	

DRAWING INDEX	
1.	Cover Sheet
1.1	General Notes
1.2	Specifications
2.	Elevations
3.	Floor Plan
3.1	Framing Details
3.2	Framing Details
4.	Electrical Plan
5.	Cross Section
6.	Blocking Plan

THIS PLAN MAY BE REVERSED OR MIRRORED.

#### ACCESSIBILITY EXCEPTIONS

1103.2.7 Raised areas. Raised areas used primarily for purposes of security, life safety, or fire safety including but not limited to, observation galleries, prison guard towers, fire towers or life guard stands are not required to be accessible or to be served by an accessible route.

1103.2.10 Single occupant structures. Single occupant structures accessed only by passageways below grade or elevated above ground including but not limited to, toll booths that are accessed by underground tunnels are not required to be accessible.  
Note: Single occupant guard structures will be placed on and elevated entrance island to the park that does not have an accessible route.

#### SPECIAL LIMITATIONS

Adequate handicapped restroom facilities to handle this additional occupant load created by the addition of this building to a site shall be provided in an adjacent building on the same property. The local official having jurisdiction shall verify the existing facilities.

#### THERMAL ZONE

This buildings design meets envelope requirements for thermal zone 5a. Lighting and mechanical energy to be determined on-site by others per the local authority having jurisdiction.

#### ATTENTION LOCAL BUILDING OFFICIAL

All work to be completed on-site is to be in compliance with all state and local codes and is subject to review, approval, and inspection by the local authority having jurisdiction. This building is designed for installation on a permanent foundation and is not intended to be moved once installed. All on-site work shall be performed by a licensed contractor with experience in the setup of modular buildings. The following list is not all inclusive, nor does it limit the items of work or materials that may be required for complete installation.

1. Complete foundation support and anchorage system.
2. Ramps, stairs and general access to building.
3. Electrical service connection (including feeders) to the building.

COMPONENTS AND CLADDING WIND LOADS		
Component	End Zone (psf)	Interior Zone (psf)
Windows & Siding	+17.7/-23.7	+17.2/-19.2
Doors	+15/-18.4	+15/-18.5
Roof Cladding	+10/-44.6	+10/-17.7
Roof Overhangs	-41.9	-25.5

#### NOTICE

These drawings are applicable only to the elements and loading criteria specifically provided herein. These drawings shall not be construed in any way to specify, certify or design any aspects of the building not contained herein. Elements not contained herein are to be constructed in accordance with the prescriptive requirements of the adopted building code or designed by other registered design professionals, as applicable. Specified design criteria are based solely on information provided by the client and must be verified and approved by the local authority having jurisdiction. NTA, Inc. is not responsible for fabrication or erection. If it is suspected that these drawings have been modified, substituted or altered in any way, contact NTA, Inc. directly to obtain a file copy.

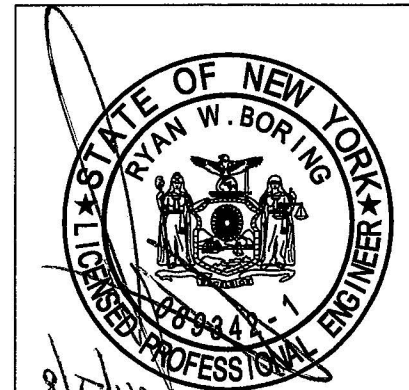

IT IS A VIOLATION OF NEW YORK EDUCATION LAW ARTICLE 145 FOR ANY PERSON, UNLESS ACTING UNDER THE DIRECTION OF A LICENSED PROFESSIONAL ENGINEER, TO ALTER THIS DOCUMENT IN ANY WAY.

NTA Engineering, PC, 7690 W. Nottingham Dr., Nappanee, IN 46550

These documents are applicable only to the elements and loading criteria specifically provided herein. These documents shall not be construed in any way to specify, certify or design any aspects of the building not contained herein. Specified design criteria are based solely on information provided by the client and must be verified and approved by the local authority having jurisdiction. NTA Engineering is not responsible for fabrication or erection. It is in violation of New York Educational Law Article 145 for any person, unless acting under the direction of a licensed engineer to alter this document in any way. If it is suspected that these drawings have been modified, substituted or altered in any way, contact NTA Engineering, PC at (574) 773-7976 to obtain a file copy.

0104 2008-05-28

REVISIONS:	SCALE: NTS	APPROVED BY:	<b>Twin Modular Services Inc.</b> Blackwood, NJ	TITLE: COVER SHEET	JOB NO: TMS082814-19
	DATE: 08/29/2014	DRAWN BY: EAB		MODEL: 66 SCALE HOUSE	DRAWING NO: 1

**WOOD FRAMING**

- Structural sawn lumber shall be identified by a grade mark in accordance with DOC PS 20.
- Approved end-jointed lumber may be use interchangeably with solid-sawn member of the same species and grade except in fire rated assemblies.
- Structural sheathing shall be rated and labeled for compliance with DOC PS 1 or DOC PS 2.
- LVL members shall have the following minimum properties, E=2.0, F<sub>v</sub>=2800 psi, unless noted otherwise.
- All wood shall have a moisture content of 19% or less at the time of construction.
- Wood framing members, including wood sheathing, that rest on exterior foundation walls and are less than 8" from exposed earth each shall be naturally durable or preservative treated.
- Wood members shall be cut and joined so no gap larger than 1/8" exists between members.
- Wood in contact with concrete or masonry shall be naturally durable or preservative treated in accordance with AVPA use category UC4C and properly identified as preservative treated.
- Nails and staples shall conform to ASTM F1667. Nails with shank diameters of 0.099" but not larger than 0.142" shall have a minimum average bending yield strength, F<sub>b</sub> = 100 ksi.
- Fasteners shall be installed to avoid splitting of the wood members. If splitting occurs, the connection shall be made by alternate means or otherwise reinforced under the direction of the design engineer.
- Fasteners shall be driven so their head or crown is flush with the surface of the wood member or sheathing. Overdriven fasteners shall be replaced.
- Bolts shall conform to ASTM A307 meeting the requirements of ANSI/ASME B18.2.1 for full-body diameter bolts. Screws and lag screws shall conform to ANSI B18.2.1 and ANSI B18.6.1, respectively.
- Bolt holes shall be at least a minimum of 1/32" and no more than a maximum of 1/16" larger than the bolt diameter.
- Bolt nuts shall be finger-tight plus 1/3 to 1/2 turn with a hand wrench.
- Connection hardware shall be the brand and model specified. Alternate connectors shall be submitted to the design engineer for approval.
- Unless otherwise noted, connectors shall be installed with the maximum number and size of fasteners as required in the manufacturer's installation instructions.
- Prefabricated wood I-joist and structural composite lumber shall not be notched or drilled except where permitted by the manufacturer's recommendations.
- Plywood beams shall be detailed and fabricated in accordance with the latest edition of APA Plywood Design Specification Supplement 5 - Design & Fabrication of All-Plywood Beams.
- Douglas Fir, Hem Fir, or Southern Yellow Pine may be substituted for Spruce-Pine-Fir using an equal size and grade.

**CORROSION PROTECTION**

- Metal framing, connectors, fasteners, and flashing in contact with preservative treated or fire retardant treated wood members shall be hot-dipped zinc coated galvanized steel, stainless steel, silicon bronze, copper, or otherwise protected from the corrosive action of the wood member.
- A barrier between the treated members can be used when approved by the design engineer.
- Selection of the appropriate connector and fastener coating shall be based on the intended end use of the connector or fastener and the chemical preservative used in the the treatment of the member for which it is in contact.
- Where connection hardware is used, such as joint hangers, fasteners used shall be made of the same material as the connection hardware.
- Corrosion protection of metal connectors, fasteners, and flashing based on galvanized or stainless steel materials shall be in accordance with the table below.

Product Coatings	Hot Dipped Galvanized (ASTM A153)		Stainless Steel
	G90	G185	
Untreated Wood SBX/DOT CCA-C	Yes	Yes	Yes
ACQ-C & ACQ-B CBA-A & CA-B NON-DOT No Ammonia and Not Rated For Ground Contact	No	Yes	Yes
Unknown Preservative, Contains Ammonia, Rated For Ground Contact or ACZA	No	No	Yes

SBX = DOT Sodium Borate, CCA-C = Chromated Copper Arsenate, ACQ-C & ACQ-D = Alkaline Copper Quat, CBA-A & CA-B = Copper Azote, Non-DOT = Other Borate, ACZA = Ammoniacal Copper Zinc Arsenate

**COASTAL CORROSION PROTECTION**

- The corrosion protection requirements in this sections shall apply to all structures located within 3000' landward of the mean high-tide waterline for all metal components or connectors not contained within the pressure envelope of the structure.
- Fasteners or bolts less than 5/8" in diameter shall be Type 316L stainless steel. Fasteners or bolts 5/8" or larger shall be hot dip galvanized per ASTM A653 or ASTM A153 with a zinc coating thickness of 1.85 oz of zinc per square foot of surface area (G185).
- Connection hardware, such as pre-formed connectors, steel plates, or steel straps, exposed to weather and having a base metal thickness equal to or less than 1/8" shall be Type 303, 304, 305 or 316 stainless steel. Steel exposed to weather having a base metal thickness greater than 1/8" shall be hot dip galvanized per ASTM A653 or ASTM A153 with a zinc coating thickness of 1.85 oz of zinc per square foot of surface area (G185) or painted using one of the following formulations:
  - Epoxy-polyamide
  - Coal-tar epoxy-polyamide
  - Zinc chromate-vinyl butyral primer with asphaltic mastic
- Contact between dissimilar materials (stainless steel and carbon steel) shall be avoided.

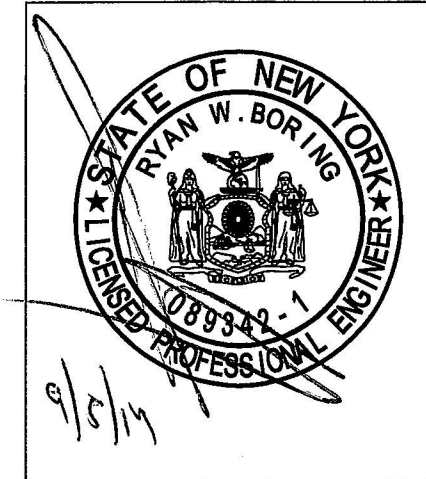

IT IS A VIOLATION OF NEW YORK EDUCATION LAW ARTICLE 145 FOR ANY PERSON, UNLESS ACTING UNDER THE DIRECTION OF A LICENSED PROFESSIONAL ENGINEER, TO ALTER THIS DOCUMENT IN ANY WAY.

NTA Engineering, PC, 7690 W. Nottingham Dr., Nappanee, IN 46550

These documents are applicable only to the elements and loading criteria specifically provided herein. These documents shall not be construed in any way to specify, certify or design any aspects of the building not contained herein. Specified design criteria are based solely on information provided by the client and must be verified and approved by the local authority having jurisdiction. NTA Engineering is not responsible for fabrication or erection. It is a violation of New York Educational Law Article 145 for any person, unless acting under the direction of a licensed engineer to alter this document in any way. If it is suspected that these drawings have been modified, substituted or altered in any way, contact NTA Engineering, PC at (574) 773-7975 to obtain a file copy.

08.04.2007-06-19

REVISIONS:	SCALE: NTS	APPROVED BY:	<b>Twin Modular Services Inc.</b> Blackwood, NJ	TITLE: GENERAL NOTES	JOB NO: TMS082814-19
	DATE: 08/29/2014	DRAWN BY: EAB		MODEL: 66 SCALE HOUSE	DRAWING NO: 1.1

**CHASSIS**

Type: Perimeter Main Beam: 6" C Channel 8.2 lbs per foot  
Cross Members: 6" C Channel at 24" o.c.  
Paint: Asphalt Based

**FLOOR**

Moisture Barrier: R-Max Therma Sheaths - See Insulation  
Insulation: 2 Layers R-Max Therma Sheath to Equal R-19  
Decking: 3/4" Plywood, 24" o.c. Secured Directly to Steel Frame  
Covering: 1/4" Commercial Rubber Flooring - Black  
Trim: 2" Commercial Rubber Base Trim - Black

**EXTERIOR WALLS**

Studs: 2x4 Stud Grade SPF at 16" o.c.  
Bottom Plate: Single 2x4 #3 SPF  
Top Plate: Single 2x4 #3 SPF  
Wall Height: 8'-3"  
Finished Ceiling Height: 7'-8" AFF  
Insulation: R-13 Kraft-Backed Batts  
Interior Wall Covering: FRP Over 1/4" Plywood Glued and Fastened to Studs - White

**ROOF**

Type: Rafter, 2x8 #3 SPF at 16" o.c. Bow Type  
Ceiling: 2'x4' T-Grid Drop Ceiling at 7'-8" AFF  
Insulation: R-30 Kraft Unfaced Fiberglass Batts  
Overhang: 6" Overhang All Sides

**ELECTRICAL**

Main Distribution Panel: Interior, NEMA 3R) 100 AMP 120/240 Volt, Single Phase, 3 wire, 60 HZ with Ground  
Raceway: Minimum #14/2 with Ground 90 Deg. C Type MC Copper  
Interior Lights: 2'x2' Two Tube Lay-In Florescent Troffer Per Print  
Exterior Lights: 150 Watt Quartz Halogen Security Light (Weatherproof)  
Switches: 120V 15 Amp Single Pole Per Print  
Recepts: (4) 120V 15 AMP Duplex Per Print

**HVAC**

Heating: 208/240V, 20 Amp, 3000 Watt Wall Heater with Fan  
Air Conditioning: 110V (Dedicated Circuit) 8000 BTU Wall Mount

**EXTERIOR WINDOWS AND DOORS**

Doors: 36x80 Steel Door with 22"x22" Window (Safety Glazed), Ball Hardware and Closer  
Windows: (2) 36"x39" Horizontal Slider, Vinyl Clad, Thermal Pane with Vinyl Trim  
Windows: (1) 36" x 39" Vinyl Clad, Thermal Pane with vinyl trim

**EXTERIOR FINISHES**

Siding: 0.19 Aluminum Light Gray  
Trim: 0.19 Aluminum Dark Gray  
Wall Sheathing: 7/16" OSB, 24/16 APA Span Index Rating  
Roof Sheathing: 1/2" CDX Plywood, 24/16 Span Rating  
Roof: 0.45 EPDM Rubber Roofing

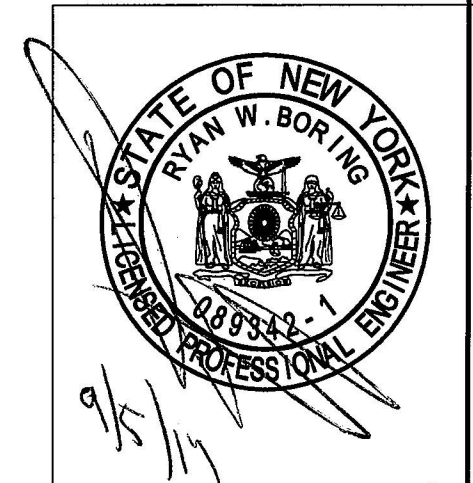

IT IS A VIOLATION OF NEW YORK EDUCATION LAW ARTICLE 145 FOR ANY PERSON, UNLESS ACTING UNDER THE DIRECTION OF A LICENSED PROFESSIONAL ENGINEER, TO ALTER THIS DOCUMENT IN ANY WAY.

NTA Engineering, PC, 7690 W. Nottingham Dr., Nappanee, IN 46550

These documents are applicable only to the elements and loading criteria specifically provided herein. These documents shall not be construed in any way to specify, certify or design any aspects of the building not contained herein. Specified design criteria are based solely on information provided by the client and must be verified and approved by the local authority having jurisdiction. NTA Engineering is not responsible for fabrication or erection. It is in violation of New York Educational Law Article 145 for any person, unless acting under the direction of a licensed engineer to alter this document in any way. If it is suspected that these drawings have been modified, substituted or altered in any way, contact NTA Engineering, PC at (574) 773-7975 to obtain a file copy.

06.04 2007-06-19

REVISIONS:	SCALE: NTS	APPROVED BY:	<b>Twin Modular Services Inc.</b> Blackwood, NJ	TITLE: SPECIFICATIONS	JOB NO: TMS082814-19
	DATE: 08/29/2014	DRAWN BY: EAB		MODEL: 66 SCALE HOUSE	DRAWING NO: 1.2

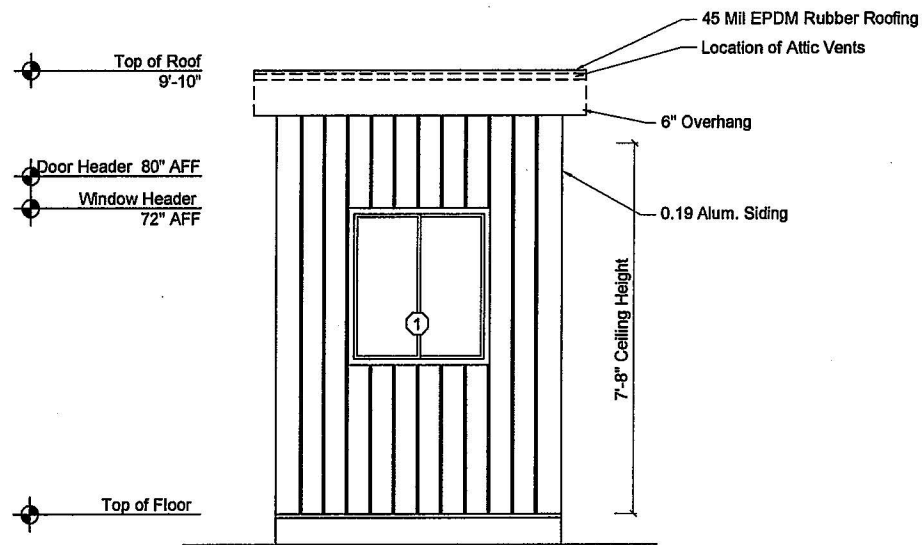

FRONT ELEVATION  
SCALE: 1/4" = 1'-0"

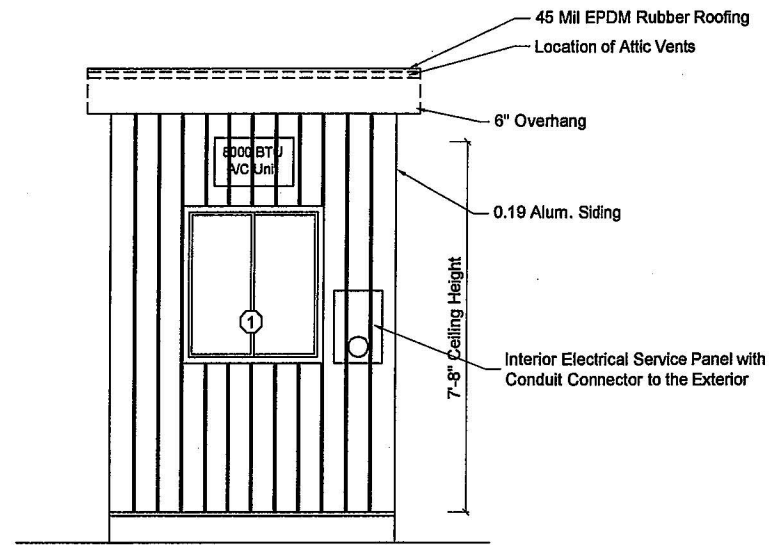

REAR ELEVATION  
SCALE: 1/4" = 1'-0"

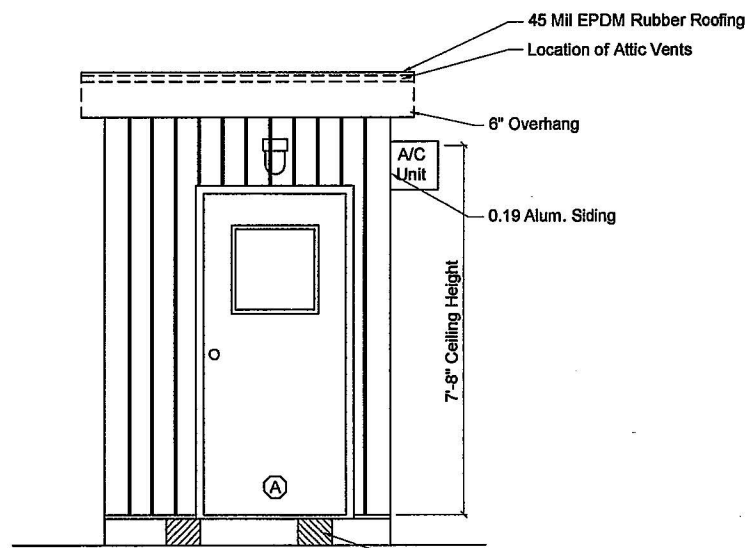

LEFT ELEVATION  
SCALE: 1/4" = 1'-0"

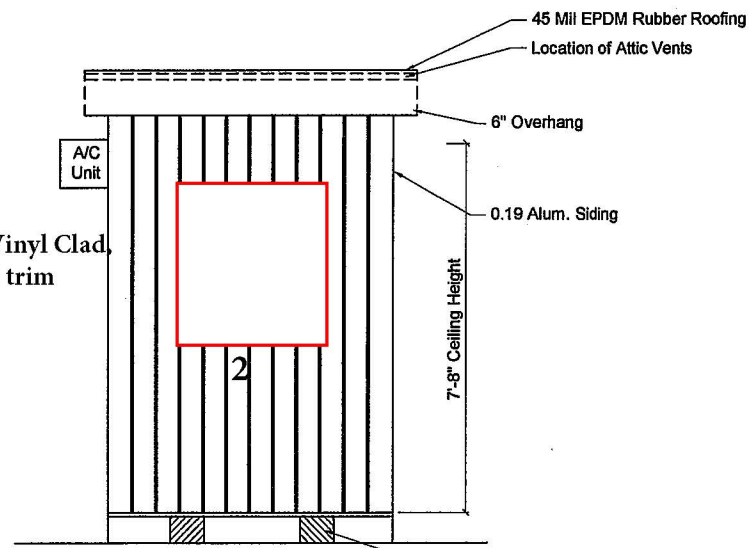

RIGHT ELEVATION  
SCALE: 1/4" = 1'-0"

Windows: (1) 36" x 39" Vinyl Clad Thermal Pane with vinyl trim

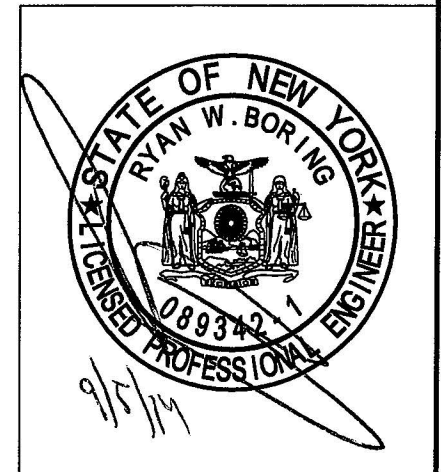

IT IS A VIOLATION OF NEW YORK EDUCATION LAW ARTICLE 145 FOR ANY PERSON, UNLESS ACTING UNDER THE DIRECTION OF A LICENSED PROFESSIONAL ENGINEER, TO ALTER THIS DOCUMENT IN ANY WAY.

NTA Engineering, PC, 7690 W. Nottingham Dr., Nappanee, IN 46550

These documents are applicable only to the elements and loading criteria specifically provided herein. These documents shall not be construed in any way to specify, certify or design any aspects of the building not contained herein. Specified design criteria are based solely on information provided by the client and must be verified and approved by the local authority having jurisdiction. NTA Engineering is not responsible for fabrication or erection. It is in violation of New York Education Law Article 145 for any person, unless acting under the direction of a licensed engineer to alter this document in any way. If it is suspected that these drawings have been modified, substituted or altered in any way, contact NTA Engineering, PC at (574) 773-7975 to obtain a file copy.

DOOR SCHEDULE	
Mark	Description
A	36" x 80" Steel Door with 22x22 Vision, Closure and Lockset
WINDOW SCHEDULE	
Mark	Description
1	36" x 39" Horizontal Slider, Vinyl Clad, Thermally Insulated, Tempered
2	36" x 39" Picture Type None Operable Vinyl Thermal

**ATTIC VENTILATION**  
Vents shall be installed to provide a total net free ventilating area not less than 1/150 of the area of the space being ventilated. Vents shall be positioned to provide cross ventilation.

96 Area /150= 0.64 sq. ft. Ventilation Required

**SITE INSTALLED ITEMS**  
Steps, rails, and decks are to be designed by others and built on-site in accordance with local codes and subject to approval by the local authority having jurisdiction.

**DISTANCE FROM EXPOSED EARTH**  
Wood framing members, including wood sheathing, that are less than 8 inches from exposed earth shall be of naturally durable or preservative-treated wood.

REVISIONS:	SCALE: 1/2" = 1'-0"	APPROVED BY:
	DATE: 08/29/2014	DRAWN BY: EAB

**Twin Modular Services Inc.**  
Blackwood, NJ

TITLE: ELEVATIONS PLAN	JOB NO: TMS082814-19
MODEL: 66 SCALE HOUSE	DRAWING NO: 2

0105.1151 2008-12-02

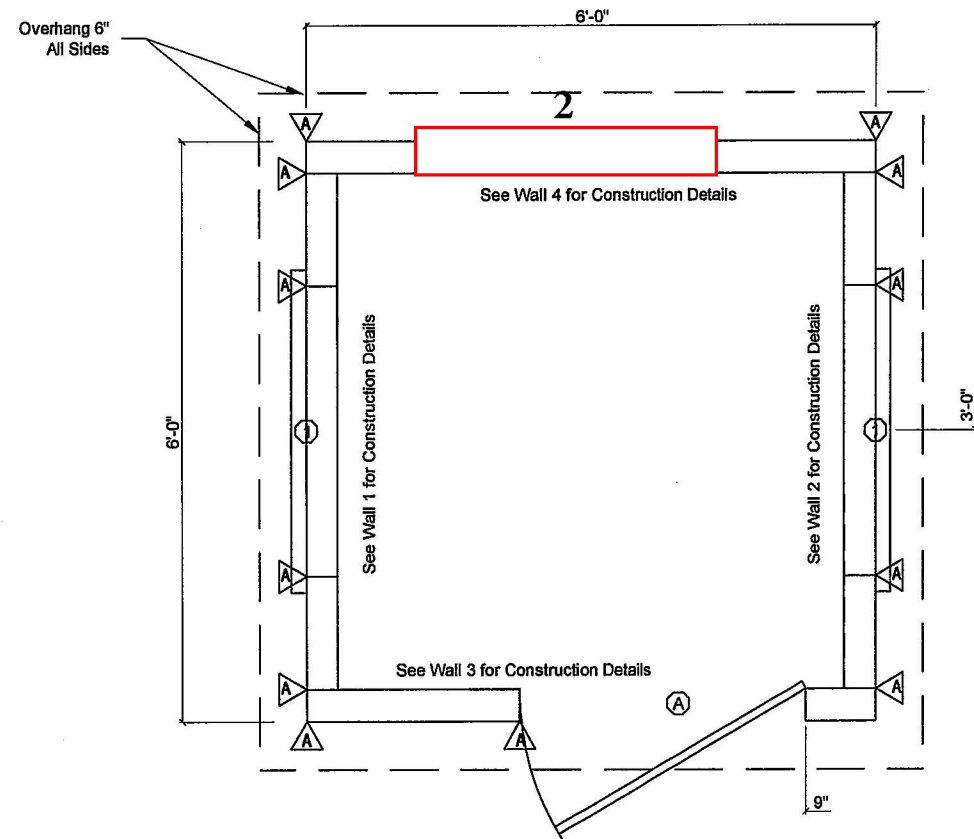

BUYER ACCEPTANCE PLAN A SIGN AND DATE

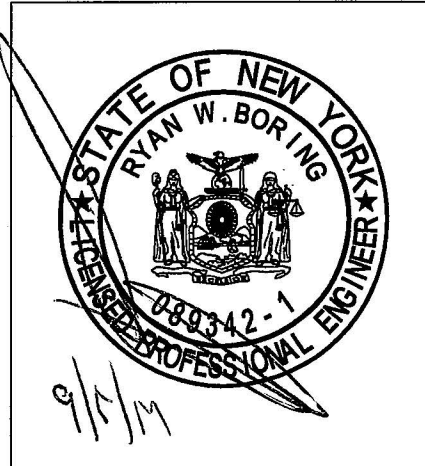

IT IS A VIOLATION OF NEW YORK EDUCATION LAW ARTICLE 145 FOR ANY PERSON, UNLESS ACTING UNDER THE DIRECTION OF A LICENSED PROFESSIONAL ENGINEER, TO ALTER THIS DOCUMENT IN ANY WAY.

NTA Engineering, PC, 7690 W. Nottingham Dr., Nappanee, IN 46550

These documents are applicable only to the elements and loading criteria specifically provided herein. These documents shall not be construed in any way to specify, certify or design any aspects of the building not contained herein. Specified design criteria are based solely on information provided by the client and must be verified and approved by the local authority having jurisdiction. NTA Engineering is not responsible for fabrication or erection. It is in violation of New York Educational Law Article 145 for any person, unless acting under the direction of a licensed engineer to alter this document in any way. If it is suspected that these drawings have been modified, substituted or altered in any way, contact NTA Engineering, PC at (574) 773-7975 to obtain a file copy.

**GENERAL**

1. All glazing within 24" arc of doors, whose bottom edge is less than 60" above the floor, and all glazing in door shall be safety glazed, tempered or acrylic plastic sheet.
2. Minimum corridor width shall not be less than 36".
3. Exterior windows and sliding doors shall be labeled as conforming to AAMA/WDMA/CSA1011/S.2/A440.
4. Windows in buildings located in windborne debris regions shall be protected in accordance with Section 301.2.1.2 of the residential code.

- SHEARWALL CONSTRUCTION**
1. Alternate holddown of equal or greater capacity may be substituted for holddowns specified.
  2. Holddowns to be installed in accordance with manufacturer's installation instructions.

SHEARWALL SCHEDULE			
Mark	Sheathing	Fastening	Framing
A	7/16" Structural Sheathing, One Side, Blocked	0.113" x 2.5" nails 6/12 (edge/field)	2x4 SPF @ 16" oc

DOOR SCHEDULE					
Mark	Description	Hardware	Header	Jack Studs	Jamb Studs
A	36" x 80" Steel Door with 22x22 Vision, Closure and Lockset	Ball Knob	(2) 2x4 #2 SPF	1	1

WINDOW SCHEDULE						
Mark	Description	Glazed Area	Vent Area	Header	Jack Studs	Jamb Studs
1	36" x 39" Horizontal Slider, Vinyl Clad, Thermally Insulated, Tempered	9.75 ft <sup>2</sup>	4.87 ft <sup>2</sup>	(2) 2x4 #2 SPF	1	1

**2** 36"x39" Picture Type None Operable Vinyl Thermal

REVISIONS:	SCALE:	APPROVED BY:	
	1/2" = 1'-0"		
	DATE:	DRAWN BY:	
	08/29/2014	EAB	

**Twin Modular Services Inc.**  
Blackwood , NJ

TITLE:	FLOOR PLAN	JOB NO:	0106 2008-09-23
MODEL:	66 SCALE HOUSE	TMS082814-19	
		DRAWING NO:	3

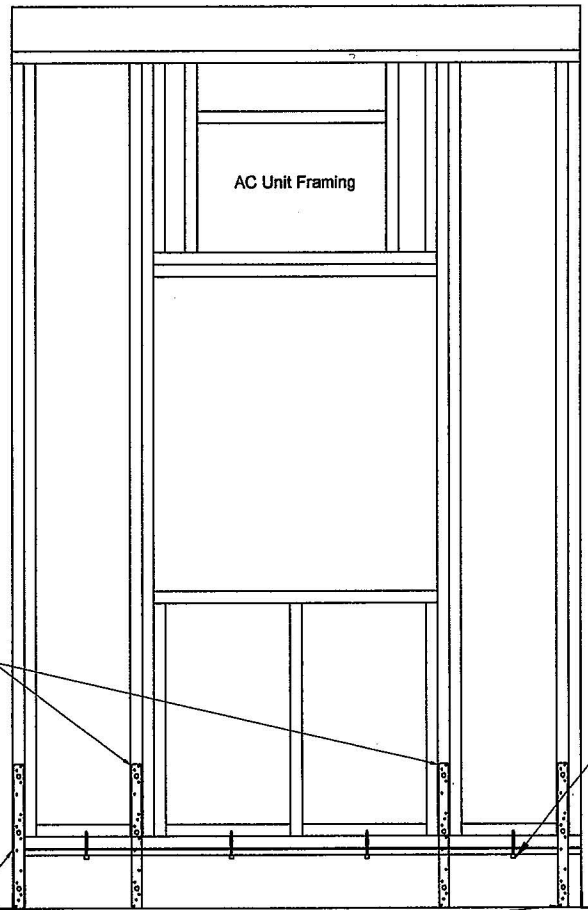

Walls 1 and 2 Elevation

AC Unit Framing

(1) CS22 Strap from Wall Stud to Frame each Labeled Location

3"x3"x15" Steel Angle 1/8" Thick Welded to Steel "C" Channel and Screwed to Wood Corner Framing Using (10) Simpson SDS 1/4"x1 1/2" Screws Each Corner

(1) 1/4" x 3" Torx Screw Add Blocking Between Studs Each Labeled Location

3"x3"x15" Steel Angle 1/8" Thick Welded to Steel "C" Channel and Screwed to Wood Corner Framing Using (10) Simpson SDS 1/4"x1 1/2" Screws Each Corner

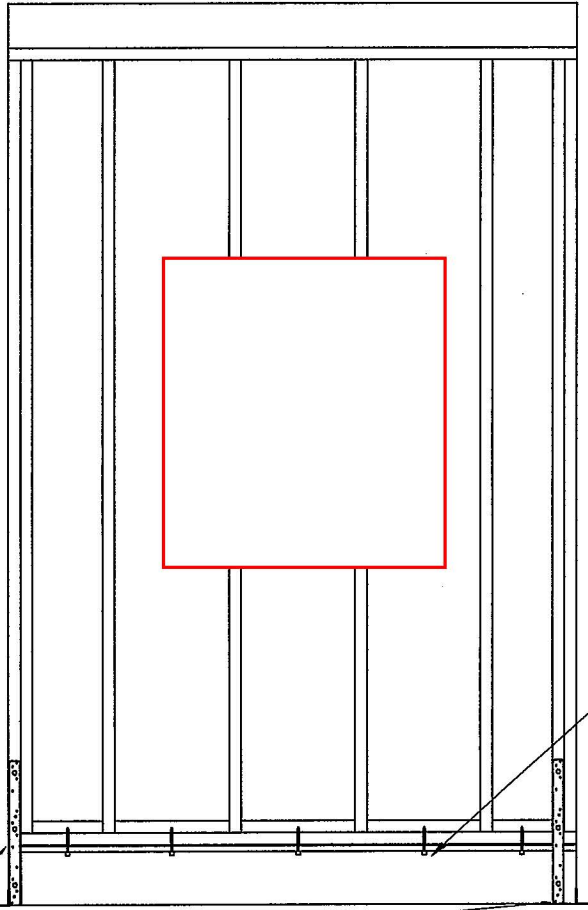

Wall 4 Elevation

(1) 1/4" x 3" Torx Screw Add Blocking Between Studs Each Labeled Location

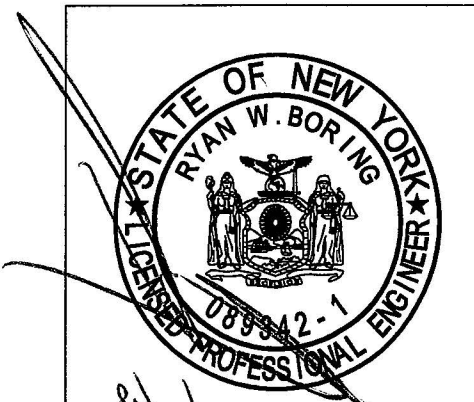

9/15/14

IT IS A VIOLATION OF NEW YORK EDUCATION LAW ARTICLE 145 FOR ANY PERSON, UNLESS ACTING UNDER THE DIRECTION OF A LICENSED PROFESSIONAL ENGINEER, TO ALTER THIS DOCUMENT IN ANY WAY.

NTA Engineering, PC, 7690 W. Nottingham Dr., Nappanee, IN 46550

These documents are applicable only to the elements and loading criteria specifically provided herein. These documents shall not be construed in any way to specify, certify or design any aspects of the building not contained herein. Specified design criteria are based solely on information provided by the client and must be verified and approved by the local authority having jurisdiction. NTA Engineering is not responsible for fabrication or erection. It is in violation of New York Educational Law Article 145 for any person, unless acting under the direction of a licensed engineer to alter this document in any way. If it is suspected that these drawings have been modified, substituted or altered in any way, contact NTA Engineering, PC at (574) 773-7875 to obtain a file copy.

0106 2008-09-23

REVISIONS:	SCALE:	APPROVED BY:	<b>Twin Modular Services Inc.</b> Blackwood, NJ	TITLE:	JOB NO:
	DATE:	DRAWN BY:		FRAMING DETAILS	TMS082814-19
	08/29/2014	EAB		MODEL:	DRAWING NO:
				66 SCALE HOUSE	3.1

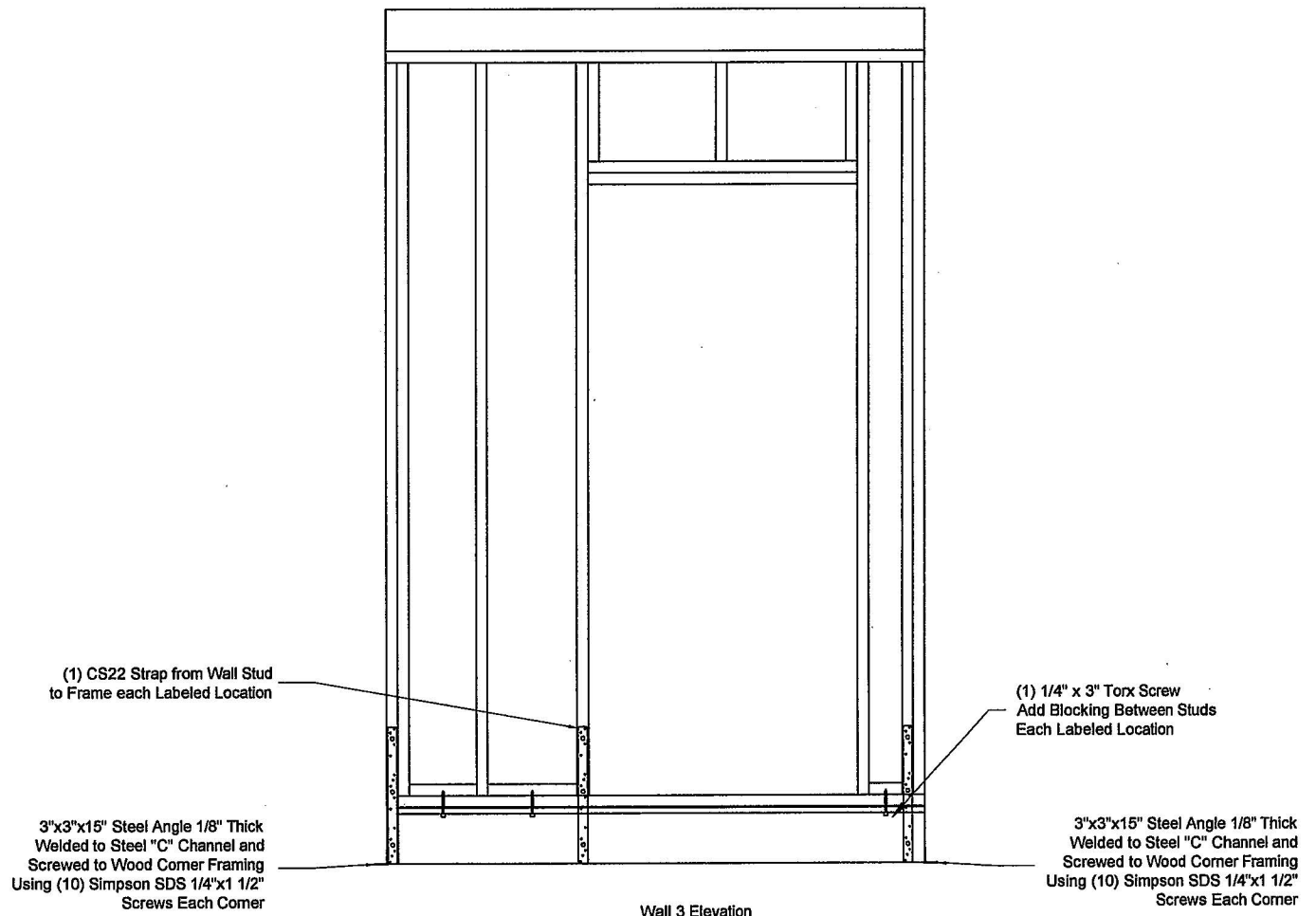

Wall 3 Elevation

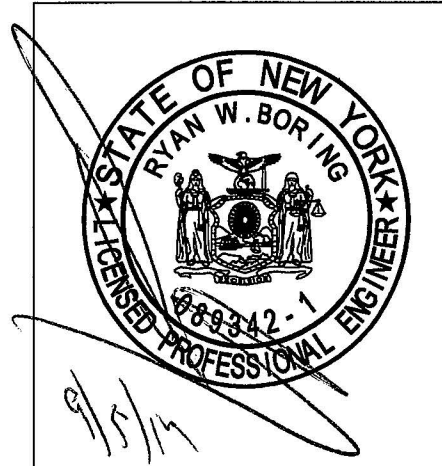

IT IS A VIOLATION OF NEW YORK EDUCATION LAW ARTICLE 145 FOR ANY PERSON, UNLESS ACTING UNDER THE DIRECTION OF A LICENSED PROFESSIONAL ENGINEER, TO ALTER THIS DOCUMENT IN ANY WAY.

NTA Engineering, PC, 7690 W. Nottingham Dr., Nappanee, IN 46550

These documents are applicable only to the elements and loading criteria specifically provided herein. These documents shall not be construed in any way to specify, certify or design any aspects of the building not contained herein. Specified design criteria are based solely on information provided by the client and must be verified and approved by the local authority having jurisdiction. NTA Engineering is not responsible for fabrication or erection. It is in violation of New York Educational Law Article 145 for any person, unless acting under the direction of a licensed engineer to alter this document in any way. If it is suspected that these drawings have been modified, substituted or altered in any way, contact NTA Engineering, PC at (574) 773-7975 to obtain a file copy.

0106 2008-09-23

REVISIONS:	SCALE:	APPROVED BY:	<b>Twin Modular Services Inc.</b> Blackwood , NJ	TITLE:	JOB NO:
	DATE:	DRAWN BY:		MODEL:	DRAWING NO:
	1/2" = 1'-0"	EAB		FRAMING DETAILS	TMS082814-19
	08/29/2014			66 SCALE HOUSE	3.2

IT IS A VIOLATION OF NEW YORK EDUCATION LAW ARTICLE 145 FOR ANY PERSON, UNLESS ACTING UNDER THE DIRECTION OF A LICENSED PROFESSIONAL ENGINEER, TO ALTER THIS DOCUMENT IN ANY WAY.

NTA Engineering, PC, 7690 W. Nottingham Dr., Nappanee, IN 46550

These documents are applicable only to the elements and loading criteria specifically provided herein. These documents shall not be construed in any way to specify, certify or design any aspects of the building not contained herein. Specified design criteria are based solely on information provided by the client and must be verified and approved by the local authority having jurisdiction. NTA Engineering is not responsible for fabrication or erection. It is in violation of New York Educational Law Article 145 for any person, unless acting under the direction of a licensed engineer to alter this document in any way. If it is suspected that these drawings have been modified, substituted or altered in any way, contact NTA Engineering, PC at (574) 773-7975 to obtain a file copy.

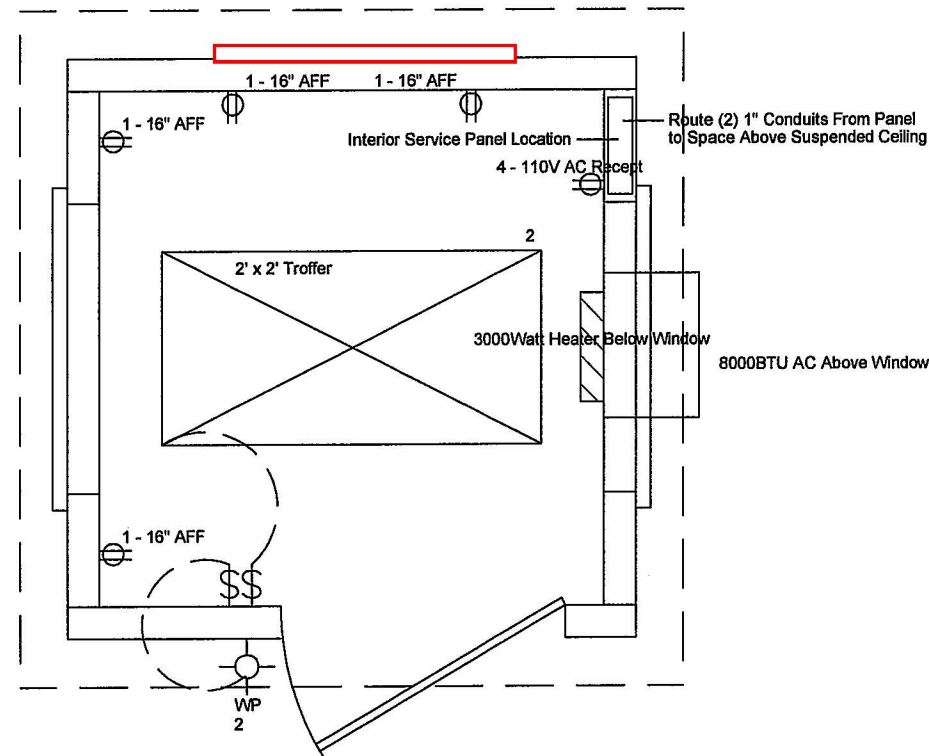

BUYER ACCEPTANCE PLAN A SIGN AND DATE

**ELECTRICAL**

1. All Receptacles to be the grounding type.
2. All Wiring to be per the edition of the NEC Listed on the Cover Page, Type MC CU with ground.
3. Main panel to be marked "Suitable For Use As Service Equipment" and be equipped with breaker/ fuse type overcurrent protection.
4. Proper thermal overload protection to be provided for all motors.
5. Disconnecting means within sight required for all motors.
6. Weather proof protection required for all outdoor lights, receptacles and disconnects.
7. Proper working clearances shall be provided and maintained for all electrical equipment.
8. All florescent fixture's required thermal protection and proper clearances from insulation, also applicable for incandescent fixture's.
9. Combination exhaust fan/light and all recessed incandescent fixture's to be with thermal protection.
10. Exit lights, if electric, must be fed from an approved emergency service connected ahead of, but not within main service disconnection means enclosure, and installed as per service requirements, or be battery backup type units.
11. Service conductors located within the perimeter of the building, shall be installed in accordance with article 230-6, per the edition of the NEC on the cover page.
12. Maximum 15 (2) tube florescent lights in 15A circuit, Maximum 10 receipts on 15A circuit, Maximum 7 (4) Tube florescent lights on a 15A circuit.
13. Maximum 20 (2) tube florescent lights in 20A circuit, Maximum 13 receipts on 20A circuit, Maximum 10 (4) Tube florescent lights on a 120A circuit.
14. All circuits and equipment shall be grounded in accordance with the appropriate articles of the National Electrical Code (NEC).
15. HVAC equipment shall be provided with readily accessible disconnects adjacent to the equipment served. A unit switch with a marked "off" position that is a part of the HVAC equipment and disconnects all ungrounded conductors shall be permitted as the disconnecting means where other disconnecting means are also provided by a readily accessible circuit breaker.
16. Prior to energizing the electrical system the interrupt rating of the main breaker must be designed by a local electrical consultant to verify compliance with NEC 110-9.
17. The electrical feeders are designed by others, site installed and subject to review and approval by the authority having jurisdiction.
18. Ceiling Luminary boxes shall be designed for the purpose and required to support a minimum of 50 lbs.

0107 2008-09-23

Electrical Specifications		
Product	Manufacturer	Model and Specifications
4,000 Watt Wall Mount Heater	Marley Fahrenheat	Model FZL4004 Fahrenheat or Equal 240V
Interior Drop In Light	Lithonia	Model 2SP8G2-U316-A12 2'x2' Lay In Trooper T-8/120V
Exterior Lighting	Lithonia	Model OFLM150Q120LPBZ 120V 150 Watt Quartz Halogen Security Light
A/C Unit	Frigidaire	8,000 BTU 110V AC Unit Unit Wall Mount Frigidare Model FRA086AT7

Note: Products may be substituted for an equal or better model.

100 Amp. ELECTRICAL PANEL SCHEDULE 120/240-V, 3-Wire, Single Phase 10 Space, 20 Circuit Minimum				DISTRIBUTION PANEL SIZING 120/240-V, 3-Wire, Single Phase	
Circuit Number & Type	Wire Size & Quantity	Breaker		Description	Receptacles (3x180) 540 W Lighting (96 sq. ft x 3w) 288 W Wall Heater 4000 W A/C 1650 W
		Trip	Pole		
1	14-2	15	1	Recepts	6478 W / 240 V = 27A Service Rating
2	14-2	15	1	Lights	
4	12-2	15	1	A/C	
3/5	12-2	20	2	Wall Heater	
6	12-2	15	2	110V Scale	
7	12-2	20	2	110V Area Light	
8	12-2	20	2	110V Spare	

ELECTRICAL LEGEND	
	208/240V Wall Mounted Heater with Fan
	2' x 2' (4 Tube) Drop In Florescent Troffer Light
	100 Amp Interior 120/240 Main Panel
	15A 110V Single Pole Toggle Switch Mounted 48" Above Floor
	15A 120V Duplex Receptacle Mounted 34" Above Floor (Unless Noted)
	Exterior Wall Mounted Light, Weatherproof
	Junction Box

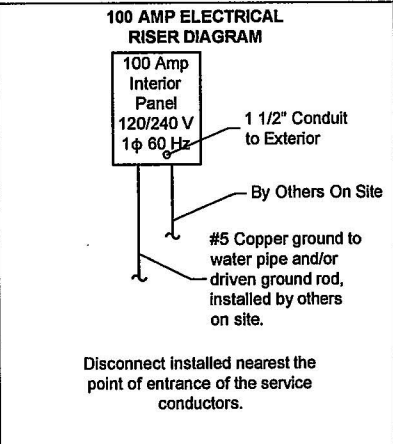

REVISIONS:	SCALE: 1/2" = 1'-0"	APPROVED BY:
	DATE: 08/29/2014	DRAWN BY: EAB

**Twin Modular Services Inc.**  
Blackwood, NJ

TITLE: ELECTRICAL PLAN	JOB NO: TMS082814-19
MODEL: 66 SCALE HOUSE	DRAWING NO: 4



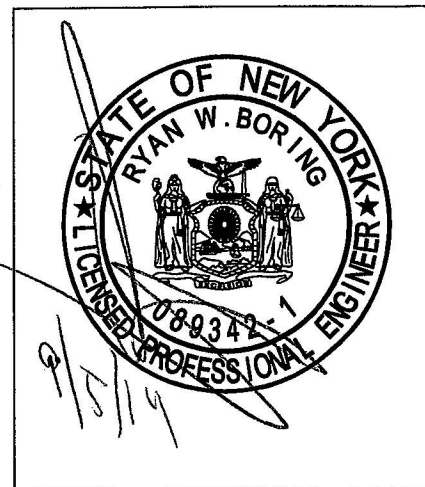
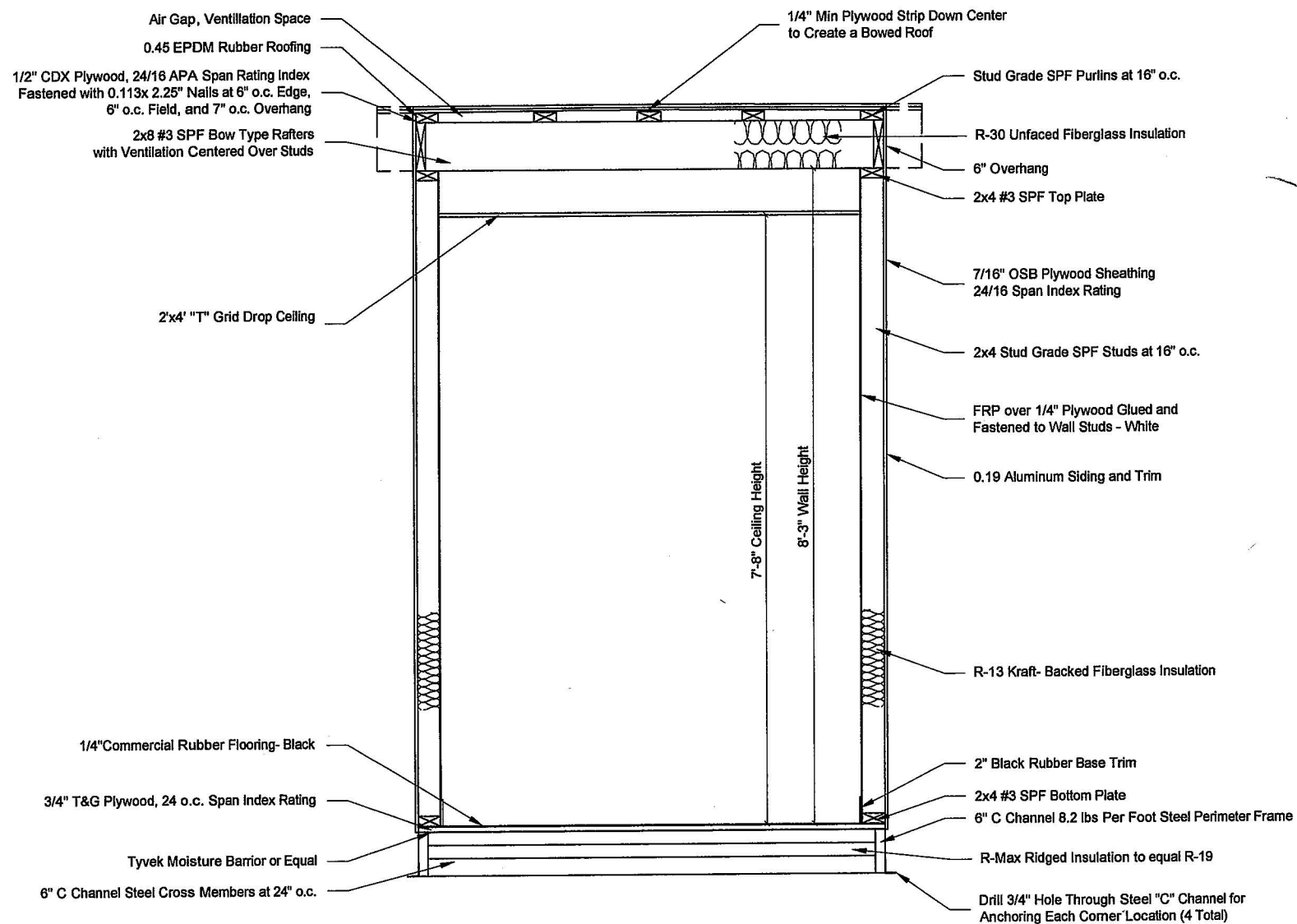

IT IS A VIOLATION OF NEW YORK EDUCATION LAW ARTICLE 145 FOR ANY PERSON, UNLESS ACTING UNDER THE DIRECTION OF A LICENSED PROFESSIONAL ENGINEER, TO ALTER THIS DOCUMENT IN ANY WAY.

NTA Engineering, PC, 7690 W. Nottingham Dr., Nappanee, IN 46550

These documents are applicable only to the elements and loading criteria specifically provided herein. These documents shall not be construed in any way to specify, certify or design any aspects of the building not contained herein. Specified design criteria are based solely on information provided by the client and must be verified and approved by the local authority having jurisdiction. NTA Engineering is not responsible for fabrication or erection. It is in violation of New York Educational Law Article 145 for any person, unless acting under the direction of a licensed engineer to alter this document in any way. If it is suspected that these drawings have been modified, substituted or altered in any way, contact NTA Engineering, PC at (574) 773-7975 to obtain a file copy.

BUYER ACCEPTANCE SIGN AND DATE

- NOTES**
- Fireblocking shall be installed at the floor and ceiling level. Fireblocking material shall be as permitted in New York Building Code Exterior joints in the building envelope that are sources of air leakage, such as floor and ceiling lines, door and windows, or any other penetrations through the building envelope shall be caulked, gasketed, weather-stripped, wrapped or otherwise sealed to limit uncontrolled air movement. Stopping materials installed on-site are subject to local review, approval and inspection.
  - In all framed walls, floors and roof/ceiling comprising elements of the building thermal envelope, a vapor retarder shall be installed on the warm-in-winter side of the insulation with the following exceptions:
    - Where the framed cavity or space is ventilated to allow moisture to escape.
  - Where required, the vapor retarder shall be comprised of any material (kraft backing, polyethylene, spray applied) approved for such use and having a perm rating of 1 or less.
  - Additional connections per standard construction manual or calculations package

0110.1150 2008-12-02

REVISIONS:	SCALE: 1/2" = 1'-0"	APPROVED BY:	<b>Twin Modular Services Inc.</b> Blackwood, NJ	TITLE: CROSS SECTION	JOB NO: TMS082814-19
	DATE: 08/29/2014	DRAWN BY: EAB		MODEL: 66 SCALE HOUSE	DRAWING NO: 5